

sedak

sedak
isopure®

data sheet

product description

sedak isopure® is the insulating glass for greater transparency.

The IGU consists of heat-strengthened or fully tempered glass. Instead of conventional up to 50mm wide black joints made of black spacers and silicone, transparent glass spacers are used on the visible sides. Thereby the glass spacer makes the usual butt joints seem to disappear.

In the edges of the IGU where the glass spacer is not necessary, a conventional sealing is used to ensure the argon or air filled cavity stays dry. The result is a nearly uninterrupted overall effect with maximum transparency and the unchanged technical properties of the insulating glass. **sedak isopure®** provides optimal ratio of manufacturing costs and best thermal values.

The **sedak isopure®** IGU is available in dimensions up to 3.6m x 20m. With this maximum format the glass spacer is located on the 3.6m vertical sides.

key benefits

- › transparency for all-glass facades
- › maximising view
- › bespoke thermal performance
- › customised coating configuration

applications

- › facades
- › roofs
- › floors

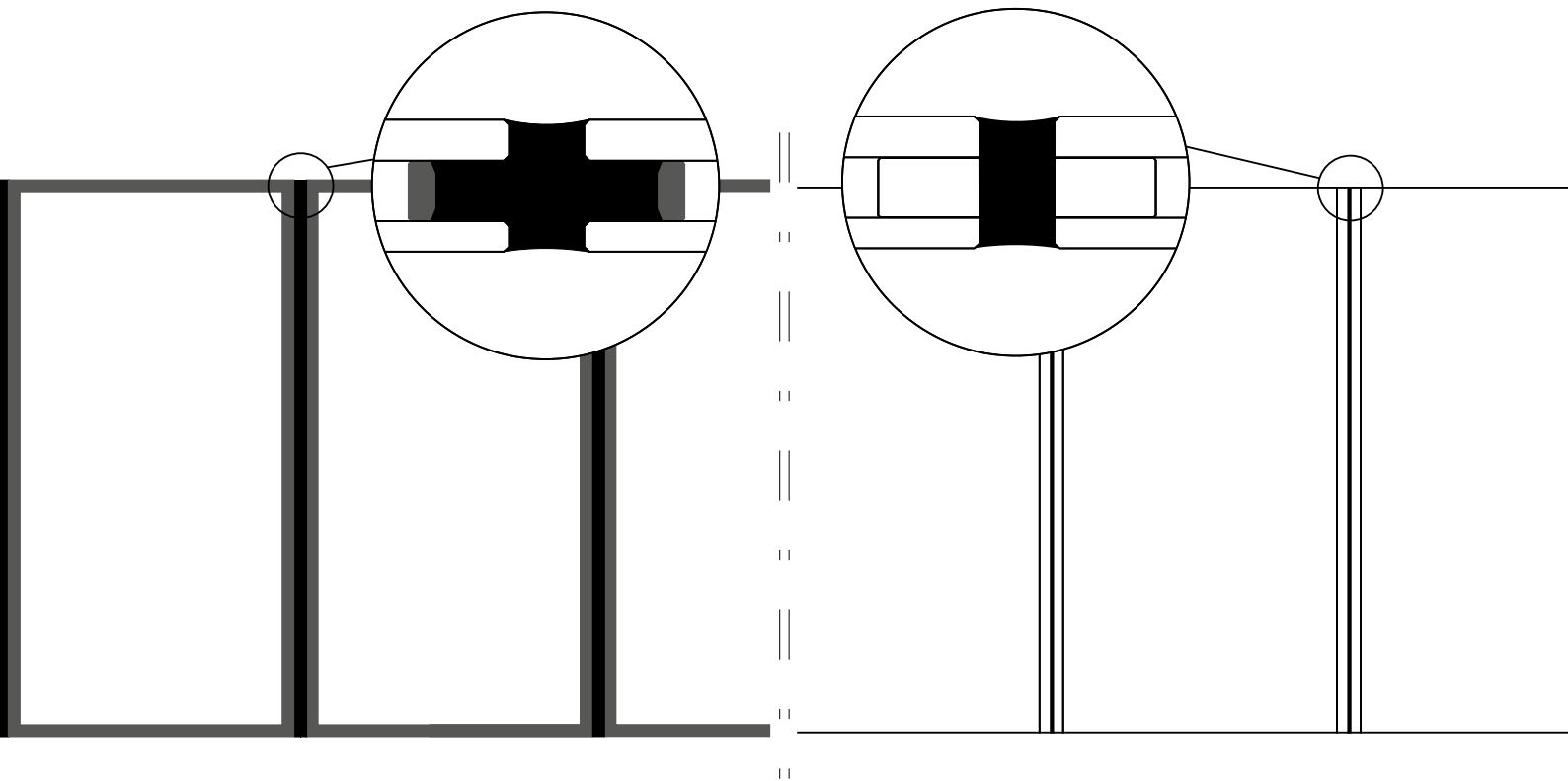

comparison joint view (front view):
IGU with conventional spacer and **sedak isopure®** with glass spacer

product specification

The glass spacer, made of low iron glass, can be used in **1, 2 or even 3 edges** (all-glass design) of the IGU. It is normally used in the two vertical edges with the aim to minimise the visual impact of standard opaque spacer. The edges of the IGU with conventional edge compound use Edgetech spacer.

facts

- › low iron glass
- › min.width required 22 mm
- › max. length 12 m
- › cavity size 14*–16 mm (argon filled)

* recommended

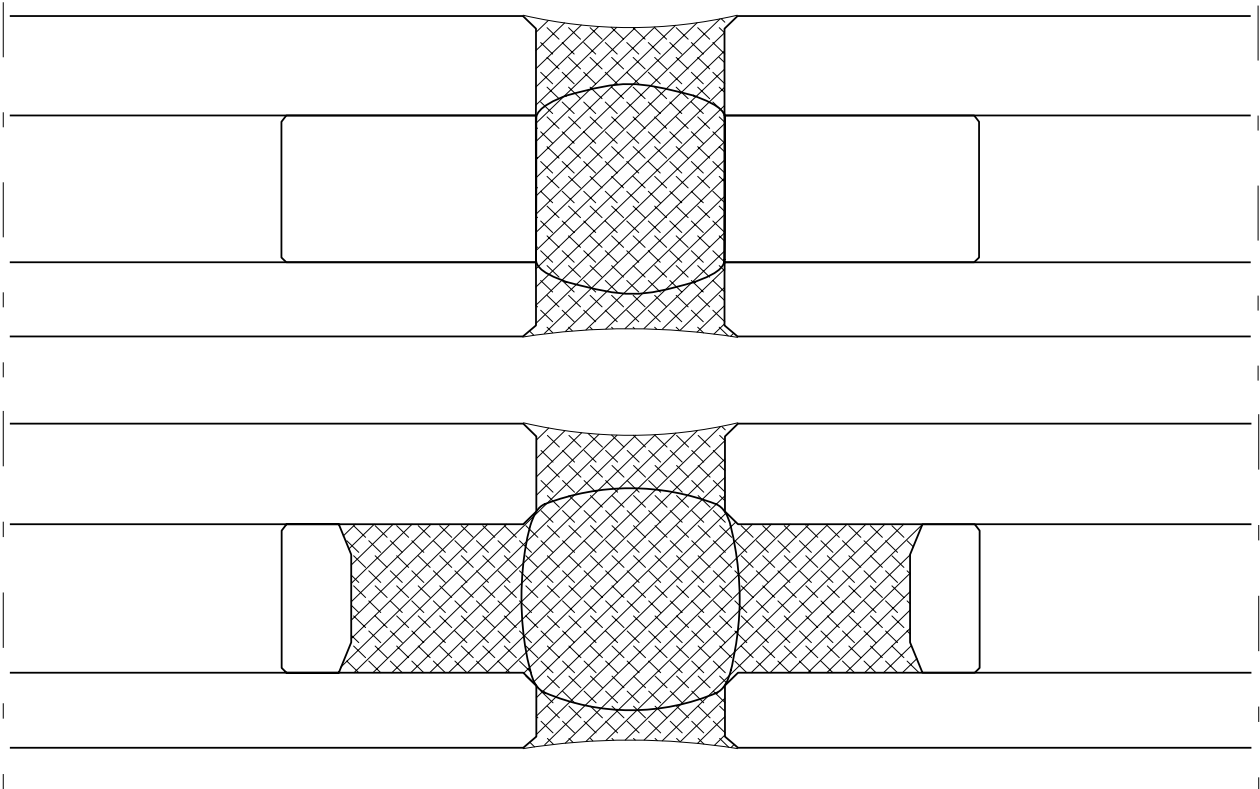
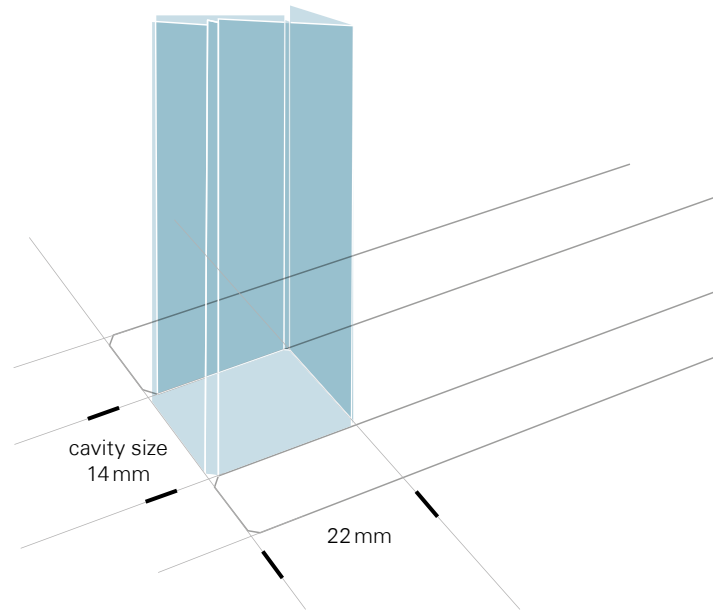

comparison joint section (top view):
sedak isopure® with glass spacer and IGU with conventional spacer

added values

Coatings

Whenever solar control, low-e or high selectivity coatings are required, it must always be ensured that the coating is not covered by the glass spacer.

Due to both, optical and adhesion purposes, the coating is always applied as a white line along the glass spacer. Pre-coated glass should always be avoided, in order to avoid edge-deletion process. The most challenging glass performances can be achieved (G value, U value, VLT, Vis.Reflection, etc.)

Silicone

Once the glass spacer has been properly assembled in the production line, the entire glass spacer edge is sealed with silicone about 1mm thick. Unless otherwise specified by the customer, the edges must be completely filled with DC 993 in black. Other colours or procedures must always be agreed in advance with the customer and the production department.

Edge printing

sedak isopure® does not require edge printing. The edges of conventional IGUs with Edgetech spacer come printed with a black ceramic frit band (other colours can be used). The minimum width of this black ceramic frit band is 15mm. Its final width is defined on a project basis.

cavity desiccant

A customized configuration of Edgetech spacer is engineered to provide sufficient desiccant to fulfil its function despite having just 2 edges with standard spacer.

Visual quality

Glass spacers are applied by hand. Air inclusions may occur in the process. A bubble with a diameter of up to 3mm per running meter or a linear air pocket with a maximum width of 0.5 to 1mm over a length of up to 15mm are within the tolerance. In the area of the corners the following can occur:

5 bubbles smaller than 1mm plus 2 bubbles up to 3mm.

The visual quality check of insulating glass is done at a distance of 1m perpendicular to the glass surface.

Load-bearing capacity

The load-bearing capacity of the glass spacer is very limited. This means that under no circumstances may a permanent load be applied to it. For short-term loads such as installation work on the glass, maximum shear forces of 0.02 N/mm² may be applied.

IGU max deflection

In principal the same possible IGU deflection limit as with a standard IGU (L/200) can be considered. Due to the singularity of the product, project-based technical checking may have to be run.

Handling

sedak isopure® handling should always be coordinated in advance to avoid overloading the glass spacer. For instance, thick laminates inboard of the IGU should be avoided so that the IGU can also be in-installed from the outside using suction cups.

performance values*

sedak isopure® double glazed unit (DGU)

built-up	Ug value (W/m²K) argon filling	Ug value (W/m²K) air filling	SGHCg value (sun70 / 37)
glass/10spacer/glass	1.4	1.8	0.39
glass/12spacer/glass	1.3	1.6	0.39
glass/14spacer/glass**	1.1	1.5	0.38
glass/16spacer/glass	1.0	1.4	0.38

sedak isopure® triple glazed unit (TGU)

built-up	Ug value (W/m²K) argon filling	Ug value (W/m²K) air filling	SGHCg value (sun70 / 37)
glass/10spacer/glass/ 10spacer/glass	0.8	0.8	0.36
glass/12spacer/glass/ 12spacer/glass	0.7	0.7	0.36
glass/14spacer/glass/ 14spacer/glass	0.6	0.6	0.36
glass/16spacer/glass/ 16spacer/glass	0.6	0.6	0.36

*all configurations with low-e and sun 70/37 coating
**recommended configuration

sedak GmbH & Co. KG
Einsteinring 1, 86368 Gersthofen

+49 821 2494 – 222
info@sedak.com

All rights reserved.
Subject to technical changes.
Last updated: may, 2026 | ©**sedak**

sedak.com